

**Product description**

PT811 is an accessory module that allows all of video- D-Vision cards to activate electrical devices external and receive activations of alarm from the outside.

PT908 is an additional module to be connected to PT811 to convert the 8 logic outputs in 8 relay outputs to directly control power loads up to 5 A.



PT811  
I / O Module



PT908  
Additional module Relay

**Compatibility**

The PT811 module can be used with the following D-Vision cards: **XP4-DV, DV-XP8 + TV and DV-RT4**. The module connects to the capture card via RS485 serial line.

The PT811 module connects with hard-wired to the PT811 outputs.

**Installation**

The I / O module PT811 communicates with a PC via an RS485 serial port. Rarely PCs are equipped with such doors and more easily you'll have to use one of the two serial ports (COM1 / COM2) that are actually RS232 ports. To connect the PT811 module to the RS232 ports on the PC, it must use a RS232 / 485 converter to be ordered separately (ref. SD-232485).

The PT-811 is connected to terminals A / B of the converter using a twisted pair cables ie 2 wrapped between them

**Connecting the PT811 inputs with ON / OFF switches and unstable contacts (sensors / buttons)**

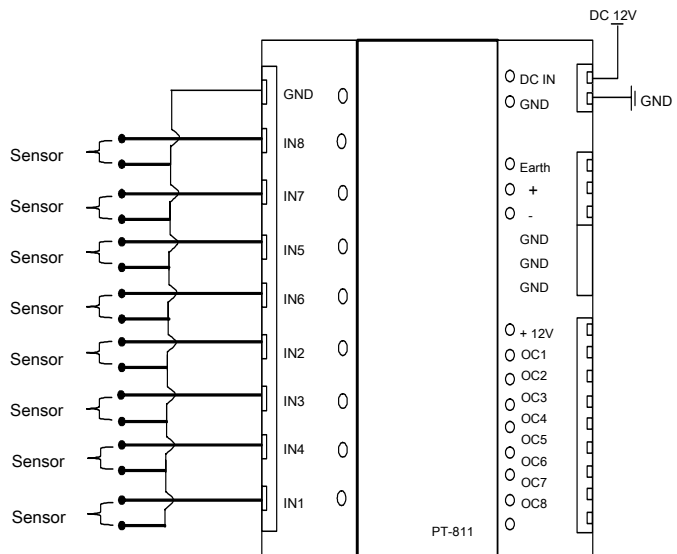
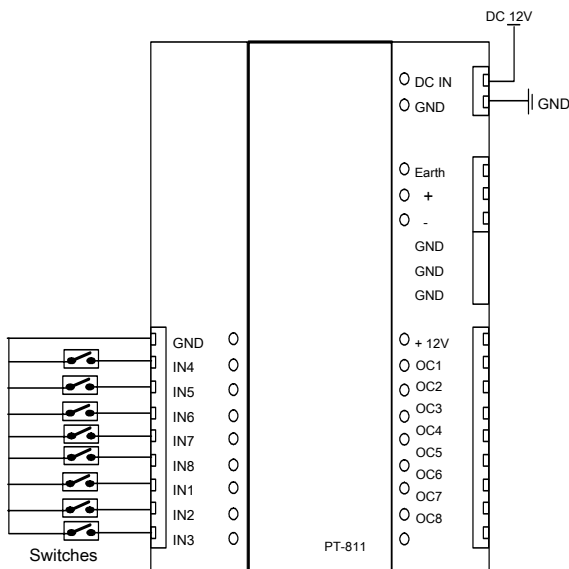

with recommended section of at least 0.5 mm. If you install more PT-811 on a same serial port is

connect in waterfall one of after the other themselves terminals A / B of each module.



The PT811 module must also be powered at 12V DC, for example with a RE-AL4 power supply (not supplied).

To connect the relay module PT-908 must physically wire the 8 OC outputs of the PT-811 OC to 8 inputs of the PT-908. They will be transformed into 8 inputs / 8 relay outputs high control capacity (5A at 220VAC, 12VDC 3A) for directly actuating the most common types of load (lighting, alarms, etc.).

**Expandability**

E can install up to 32 PT-811 modules on each PC COM port and wire them to cover long distances from the PC (max.1200 m for each serial line). Each module will be set to a different address through the programming software S100M

**PT811 Connections**

- 8 inputs (GND, 1 ... 8) 8 Open Collector outputs
- (OC1..OC8) 12VDC power supply (+/-) RS485 (A / B)
- 
- 

**PT811 Connections**

- 8 inputs (OC1..OC8) 8 5A relay
- outputs

**Programming**

Through the inputs of PT811 module it is possible to activate video recording and alarms D-Vision system. The outputs can be activated if (input or motion detection) alarm, or with a simple mouse click, even from a remote PC. For programming refer to D-Vision manual.

Connecting the PT811 module to the PC to the PT-908 module

